

# SHARP | Simply Better Living

24 in. Smart Microwave Drawer™ Oven

950  
WATTS

1.2  
CU. FT.

## SMD2479JS

Works with Alexa<sup>1</sup>, and the Sharp Kitchen App for iOS and Android Devices

Enjoy Hands-Free Cooking with Over 35 Alexa Voice Commands with the Amazon Alexa App or your Echo device<sup>2</sup>

"Easy Wave Open" for Quick, Touchless Opening of The Microwave Drawer™ Oven

Concealed, Touch Glass Control Panel opens to a Convenient 45° Angle.

Edge-to-Edge Stainless Steel Design with Convenient Viewing Window

Includes Built-In Airflow Control for Flush Mounting



## DESIGNED FOR YOUR DREAM KITCHEN

Over 35 convenient and simple voice commands help make the SMD2479JS Microwave Drawer™ oven a welcome addition to your smart home. What could be easier than just asking, "Alexa, defrost 1 pound of chicken" to your Amazon Echo device? Our wide selection of Alexa commands and Sensor Cook & Defrost menu items take the guesswork out of cooking. Download the Sharp Kitchen app and pair it with Alexa to enable the smart features.

The Easy Wave Open feature lets you wave up-and-down near the motion sensor for touchless operation, and the Microwave Drawer™ oven will glide open. With the touch of a button or a gentle nudge, our patented Easy Touch Automatic Drawer System smoothly closes the oven to avoid messy spills.

The concealed, Touch Glass Control panel is easy-to-see and operate at a convenient 45° angle, keeping all the controls at your fingertips when you need them. The modern stainless steel design with bright, LED interior lighting and stylish floor pattern compliments your kitchen and pairs beautifully with other stainless steel appliances.

The SMD2479JS Sharp Microwave Drawer™ oven features Built-In Airflow venting. Now you can choose the traditional "proud mount" installation or flush mounting for a streamlined finish without additional trim kits or vent deflectors. The optional pedestal accessory for the SMD2479JS slides into a standard dishwasher cutout for a built-in look without the need for custom cabinetry.



Pairing the SHARP KITCHEN APP activates the smart features and voice control.



Just Ask Alexa, "Alexa, open the microwave" for a little help in the kitchen.



Generous 17" x 16" interior is perfect for platters, casseroles & serving bowls.



Pedestal Accessory slides under the counter for hassle-free installs.

Product specifications and design are subject to change without notice.

Internal capacity calculated by measuring maximum width, depth and height. Actual capacity for holding food is less.

SHARP ELECTRONICS CORPORATION  
100 Paragon Drive, Montvale NJ, 07645  
1.800.237.4277 • shop.sharppusa.com

© 2023 Sharp Electronics Corporation. All rights reserved.

Sharp and all related trademarks are trademarks or registered trademarks of Sharp Corporation and/or its affiliated companies. All other trademarks are property of their respective owners.

**SHARP**  
Be Original.

# SHARP | Simply Better Living

24 in. Smart Microwave Drawer™ Oven

## SMD2479JS



### FEATURES

Finish	Stainless Steel
Drawer Opening	Voice, Mobile App, "Easy Wave Open" Motion Sensor or Open/Close Button
Width	24"
Capacity (cu. ft.)	1.2
Output Power (watts)	950
Interior Light	LED
Timer/Settings	Yes
Open/Close	Yes
Start/+30 Sec	Yes
Stop/Clear	Yes
Power Level	11
Clock	Yes
Multi-Stage Cooking	4
Control Lock	Yes
Demo Mode	Yes
Microwave ON Indicator	Yes
End of Cooking Reminder	Yes
Auto Start	Yes
Standby Mode	Yes

### CONTROL PANEL

Control Panel Location	Center/Top
Control Panel Type	Glass Touch, Drop-Down 45° Angle
Display Type	LCD
Display Color	White on Black Background

### COOKING / MENU PRESETS

Popcorn	Sensor
Reheat	Sensor
Defrost Settings	Ground Meat, Steaks/Chops, Boneless Poultry, Bone-in Poultry, Roast, Casserole or Soup
Sensor Cook	Baked Potatoes, Sweet Potatoes, Fish/Seafood, Brown Rice, White Rice, Quick Fresh Vegetables, Longer Fresh Vegetables, Steamer Bags, Frozen Vegetables, Ground Meat, Frozen Entrées
Melt, Soft & Warm Options	Butter, Chocolate, Ice Cream, Cream Cheese, Syrup, Dessert Topping
Other Menus	Beverage Reheat, Hot Water, Hot Cereal

### ADDITIONAL FEATURES

Works with Alexa	Yes
Mobile Application	Yes, available for iOS and Android
WiFi Connectivity	Yes
Oven Floor	Patterned Glass
Flush Mount Ready	Yes, Vent Built into the Bottom

### OPTIONAL ACCESSORIES

Product Name	Under the Counter Drawer Pedestal
Model	SKMD24U0ES
Color	Stainless Steel or Custom Panel Ready
UPC	074000620865

### ADDITIONAL SPECIFICATIONS

Power Source	120V, 60Hz / 14.5A / 1.67 KW
--------------	------------------------------

### DIMENSIONS & WEIGHT (in./lbs.) (w x h x d)

Cavity Interior (w x h x d)	17-11/32" x 7-7/8" x 16-37/64"
Product Dimensions	23-9/16" x 16" x 23-1/4"
Shipping Dimensions	29-11/16" x 21-1/2" x 29-1/16"
Product Weight / Shipping Weight	74.0 lbs. / 85.8 lbs.
Standard Mount Cutout Dimensions	22-1/8" x 15-9/16" x 23-1/2"
Flush Mount Cutout Dimensions	23-7/8" x 16-1/4" x 23-1/2"

### WARRANTY / UPC

Parts	1 year
Labor	1 year
Magnetron Tube	5 years (parts only)
UPC	074000622067

<sup>1</sup>Must register with Amazon Alexa App. <sup>2</sup>Amazon Echo device not included.

Amazon, Alexa, and all related marks are trademarks of Amazon.com, Inc. or its affiliates. Internal capacity calculated by measuring maximum width, depth and height. Actual capacity for holding food is less. Product specifications and design are subject to change without notice.

## SMD2479JS



### SPECIFICATIONS

The following are measurements only. Do not use to install microwave drawer.

For detailed installation instructions, please refer to the installation manual

#### PRODUCT DIMENSIONS

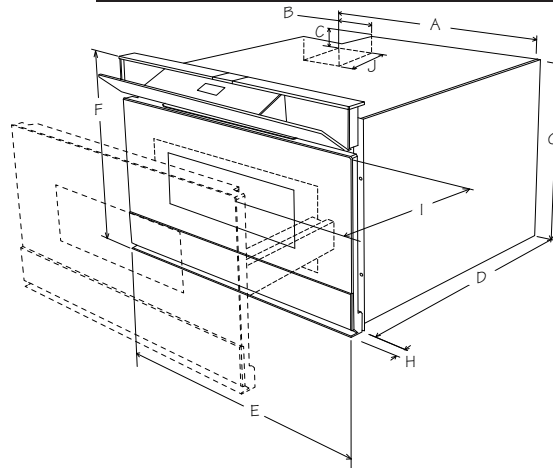

- A. 21-5/8" (549.28 mm)
- B. 4-11/16" (119.06 mm)
- C. 1-3/4" (44.45 mm)
- D. 21-7/8" (555.63 mm)
- E. 23-5/8" (600.07 mm)
- F. 16" (406.4 mm)
- G. 14-19/32" (370.68 mm)
- H. 1-17/32" (38.89 mm) door thickness
- I. 15" (381 mm) auto drawer opening
- J. 4" (101 mm)

#### STANDARD MOUNT MEASUREMENTS

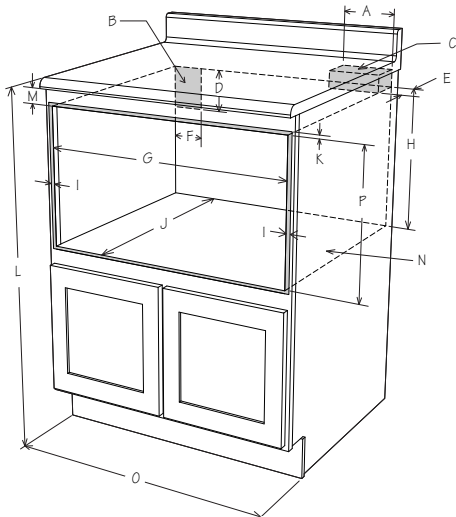

- A. 6" (152.40 mm)
- B. Suggested electrical outlet location
- C. Anti-Tip block
- D. 5" (127 mm)
- E. 3-1/2" (88.90 mm)
- F. 4" (101.60 mm)
- G. 22-1/8" (561.97 mm) opening
- H. 14-13/16" (376.24 mm) to bottom of Anti-Tip block
- I. Allow 7/8" (22.22 mm) overlap
- J. 23-1/2" (596.90 mm) min. depth
- K. Allow 7/16" (11.11 mm) overlap
- L. 36" (914.40 mm) countertop height
- M. Allow 7/16" (11.11 mm) min. space
- N. Floor must support 100 lb/45.4 kg
- O. 24" (609.60 mm) cabinet min.
- P. 15-9/16" (395.29 mm) opening

#### FLUSH MOUNT MEASUREMENTS

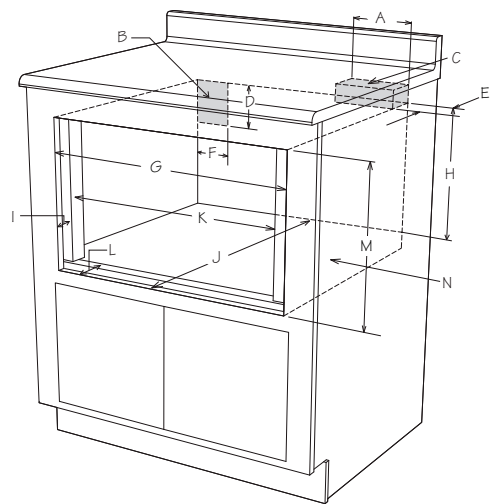

- A. 6" (152.40 mm)
- B. Suggested electrical outlet location
- C. Anti-Tip block
- D. 5" (127 mm)
- E. 3-1/2" (88.90 mm)
- F. 4" (101.60 mm)
- G. 23-7/8" (606.43 mm)
- H. 14-13/16" (376.24 mm) to bottom of Anti-Tip block
- I. 1-17/32" (38.89 mm)
- J. 23-1/2" (596.90 mm) min. depth
- K. 22-1/8" (561.97 mm)
- L. 1-17/32" (38.89 mm) to front of shelf
- M. 16-1/4" (412.75 mm) opening
- N. Floor must support 100 lb (45.4 kg)

QUESTIONS?  
1.800.BE.SHARP

#### SIMPLY BETTER LIVING

At Sharp Home Electronics Company of America, we are committed to Simply Better Living. Our innovative home appliance products are SIMPLE to use, BETTER than the competition, and encourage a HEALTHY LIFESTYLE.